

## MONO CRYSTALLINE - SHINGLED CELL TECHNOLOGY

380 / 385 / 390 / 395 / 400 / 405 / 410 / 415 Watts

# Puma Series



## Superior Performance and Reliability

Shingled technology eliminates traditional ribbon connection with shingles connected in series. By removing the soldered ribbons, the active area of the module is improved and thermal stresses are reduced - resulting in exceptional efficiency and reliability over standard interconnections.



Outstanding performance under extreme heat as well as low intensity solar radiation



Significantly low Pmax thermal coefficient



Positive Tolerance



100 % electro-luminescence tested

## Key Benefits



Higher yield per surface area



Low Pmax Temperature Coefficient



Higher yield in hot climate



25 Years Limited Product Warranty



Low LCOE



Low Resistive Losses

## Tests, Certifications and Warranties

Standard Tests	IEC 61215, IEC 61730
Factory Quality Tests	ISO 9001: 2015, ISO 14001: 2015
Certifications	Conformity to CE, PV CYCLE
Insurance	Third party liability insurance provided by Liberty Mutual
Wind and Snow Loads Testing	Module certified to withstand extreme wind (2400 Pascal) and snow loads (5400 Pascal)
Power Tolerance	Guaranteed +0%/+5% (STC condition)
Warranties	<ul style="list-style-type: none"> <li>• 25-year limited product warranty</li> <li>• 15-year manufacturer warranty on 90.30% of the nominal performance</li> <li>• 25-year transferable linear power output warranty</li> </ul>

## Linear Performance Warranty

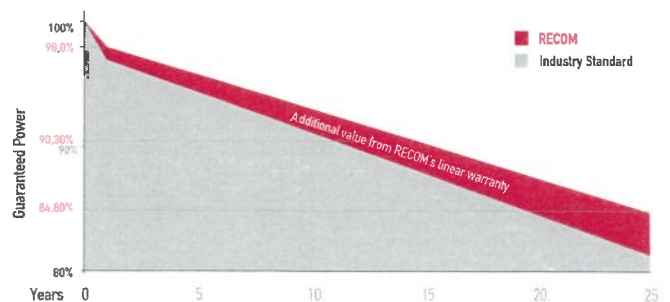

First Year Output  $\geq 98.0\%$     2-25 Year Decline  $\leq 0.55\%$     25 Year Output  $\geq 84.80\%$

# MONO CRYSTALLINE - SHINGLED CELL TECHNOLOGY

RCM-xxx-SMB (xxx=380-415)

## Electrical Characteristics

POWER CLASS <sup>(1)</sup>		380		385		390		395		400		405		410		415	
Testing Condition		STC	NMOT	STC	NMOT	STC	NMOT	STC	NMOT	STC	NMOT	STC	NMOT	STC	NMOT	STC	NMOT
Maximum Power	P <sub>max</sub> [Wp]	380	286	385	290	390	294	395	297	400	301	405	305	410	309	415	312
Maximum Power Voltage	V <sub>mp</sub> [V]	38.3	36.5	38.4	36.6	38.5	36.7	38.5	36.7	38.6	36.8	38.7	36.9	38.8	37.0	38.9	37.1
Maximum Power Current	I <sub>mp</sub> [A]	9.92	7.84	10.03	7.92	10.13	8.00	10.26	8.10	10.36	8.18	10.47	8.27	10.57	8.35	10.67	8.43
Open Circuit Voltage	V <sub>oc</sub> [V]	46.1	43.9	46.2	44.0	46.3	44.1	46.3	44.1	46.4	44.2	46.5	44.3	46.6	44.4	46.7	44.5
Short Circuit Current	I <sub>sc</sub> [A]	10.77	8.69	10.82	8.73	10.87	8.77	10.92	8.81	10.97	8.85	11.02	8.89	11.07	8.93	11.12	8.97
Module Efficiency	Eff [%]	19,4		19,6		19,9		20,2		20,4		20,7		20,9		21,2	
Maximum Series Fuse	I <sub>R</sub> [A]	20															
Maximum System Voltage	V <sub>sys</sub> [V]	1.000 VDC / 1.500 VDC (IEC)															

(1) Measurement Tolerances: P<sub>max</sub> (± 3%), I<sub>sc</sub> & V<sub>oc</sub> (± 3%) - Power Classification 0/+5W

(2) STC (Standard Testing Condition) Irradiance 1000W/m<sup>2</sup>, Cell Temperature 25°C, AM 1.5

(3) NMOT (Nominal Operating Module Temperature), Irradiance 800W/m<sup>2</sup>, NMOT, Ambient Temperature 20°C, AM 1.5, Wind Speed 1m/s

## Mechanical Data

Dimensions	1719mm x 1140mm x 35mm
Weight	22.0 Kg
Cell Type	PERC Mono-166 x 33mm - 340 pcs - M6
Front Glass	3.2mm Tempered and low iron glass + ARC
Backsheet	Anti-aging film (White)
Frame	Anodized Aluminium Alloy (Black)
Junction Box	IP68 - 2 bypass diodes
Connector	MC4 compatible
Cable	4.0mm <sup>2</sup> - Length 1200mm or customized

## Dimensions

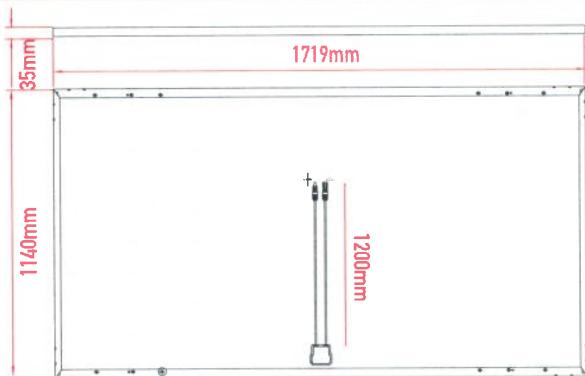

RECOM assumes no liability or responsibility for any typographical error, layout error, misinformation, any other error, omission, contained herein

www.recom-tech.com

## I-V Curve

The module relative power loss at low light irradiance of 200W/m<sup>2</sup> is less than 3%

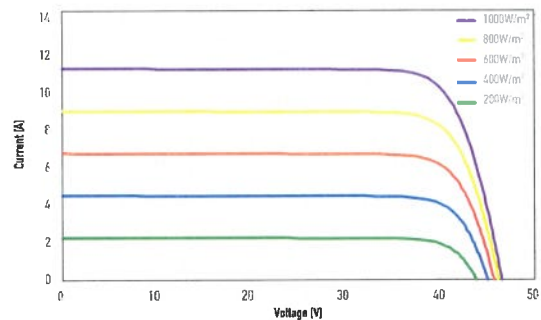

## Temperature Characteristics

P <sub>max</sub> Temperature Coefficient	-0.34% / °C
V <sub>oc</sub> Temperature Coefficient	-0.27% / °C
I <sub>sc</sub> Temperature Coefficient	+0.04% / °C
Operating Temperature	-40 ~ +85 °C
(NMOT) Nominal Module Operating Temperature	42.3 ± 2 °C

## Packing Configuration

Container	40'HC
Pieces per Pallet	31
Pallets per Container	26
Pieces per Container	806 pcs